

Computer Science

Jerzy Świątek

Systems Modelling and Analysis

Choose yourself and new technologies

L.7 Linear programming



HUMAN CAPITAL
HUMAN – BEST INVESTMENT!



Wrocław University of Technology

EUROPEAN
SOCIAL FUND



Project co-financed from the EU European Social Fund



Linear Programming

Product	P_1	P_2	Global Resurs
Resurs S_1	2	2	14
Resurs S_2	1	2	8
Resurs S_3	4	0	16
Profit/unit	2	3	

Decision variable:

x_1, x_2 - value of production product P_1, P_2 respectively

Goal function:

$$F(x_1, x_2) = 2x_1 + 3x_2$$

Constrains:

$$2x_1 + 2x_2 \leq 14$$

$$x_1 + 2x_2 \leq 8$$

$$4x_1 + 0x_2 \leq 16$$

$$x_1 \geq 0, x_2 \geq 0$$



Linear Programming

Goal function:

$$F(x_1, x_2) = 2x_1 + 3x_2$$

Constraints:

$$2x_1 + 2x_2 \leq 14$$

$$x_1 + 2x_2 \leq 8$$

$$4x_1 + 0x_2 \leq 16$$

$$x_1 \geq 0, x_2 \geq 0$$

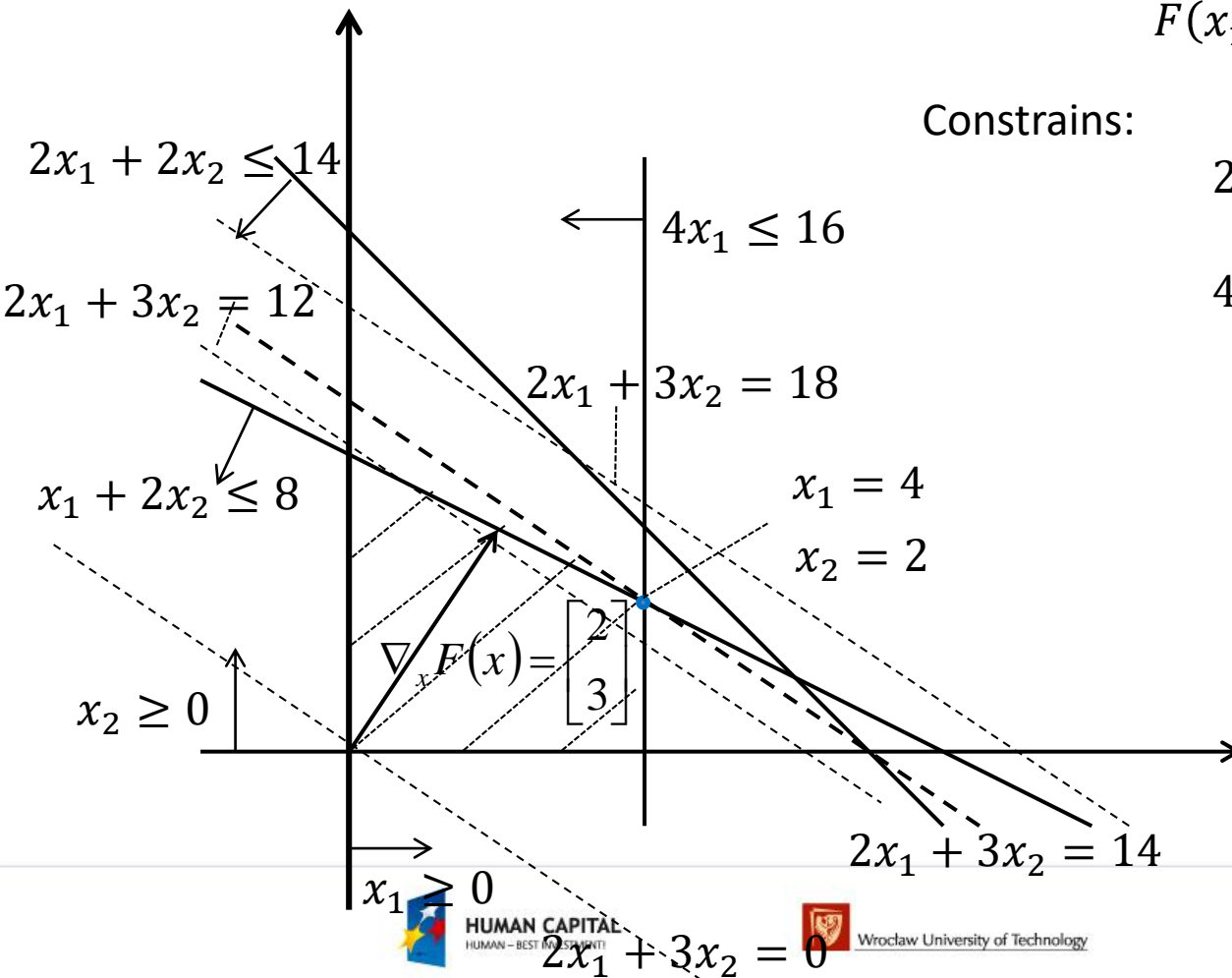



Linear Programming

Problem like before but sum of product greater than 8,

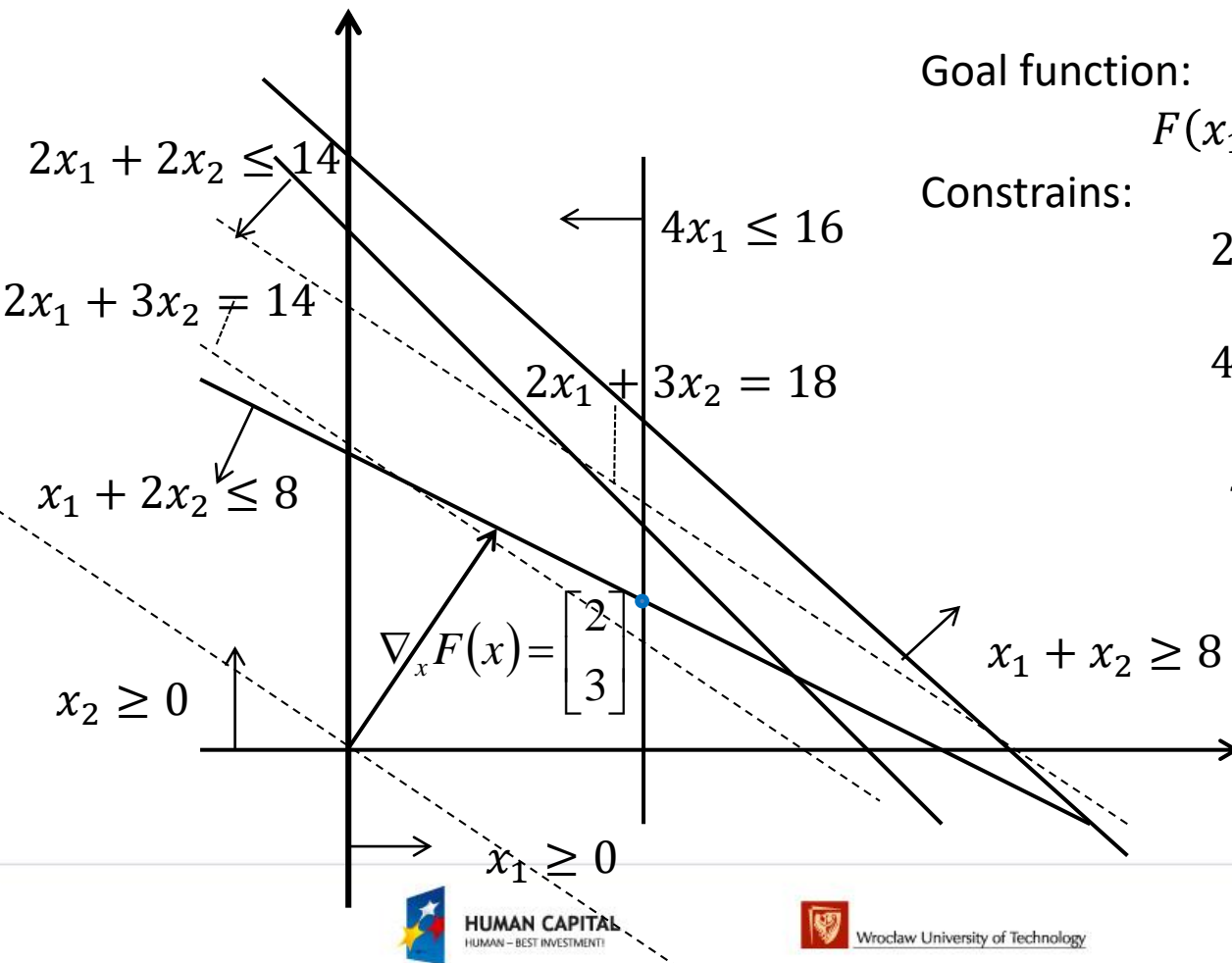

Goal function:

$$F(x_1, x_2) = 2x_1 + 3x_2$$

Constrains:

$$2x_1 + 2x_2 \leq 14$$

$$x_1 + 2x_2 \leq 8$$

$$4x_1 + 0x_2 \leq 16$$

$$x_1 + x_2 \geq 8 \quad \text{!!!!!!}$$

$$x_1 \geq 0, x_2 \geq 0$$

Solution set is empty set



Linear Programming

Problem like at the beginning, but profit of product P_2 is 4

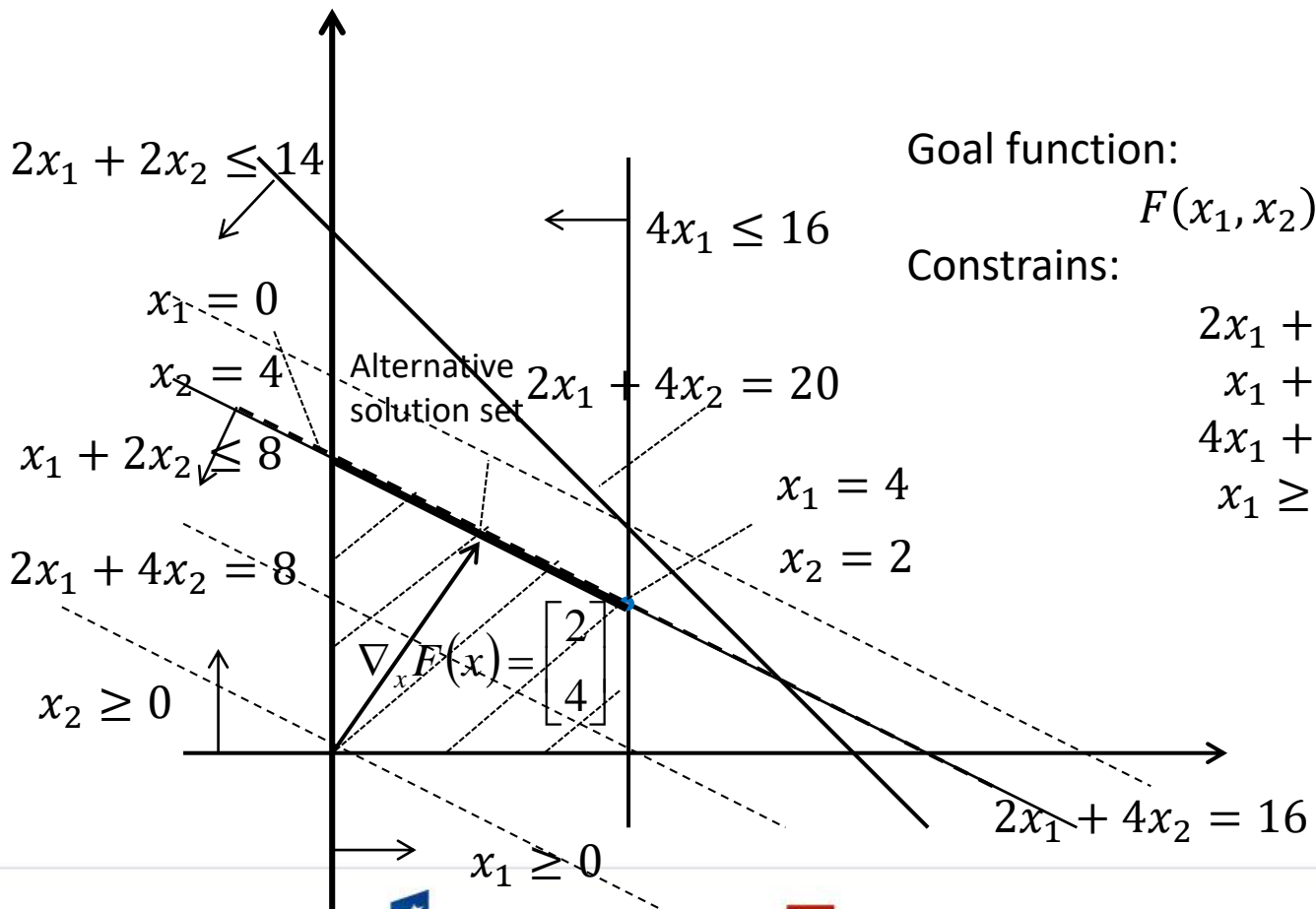

Goal function:

$$F(x_1, x_2) = 2x_1 + 4x_2$$

Constrains:

- $2x_1 + 2x_2 \leq 14$
- $x_1 + 2x_2 \leq 8$
- $4x_1 + 0x_2 \leq 16$
- $x_1 \geq 0, x_2 \geq 0$





Product	P_1	P_2	Global Resurs
Resurs S_1	2	2	Not limited
Resurs S_2	1	2	Not limited
Resurs S_3	4	0	16
Profit/unit	2	3	

Sum of products greater than 3.

Goal function:

$$F(x_1, x_2) = 2x_1 + 3x_2$$

Constrains:

$$4x_1 + 0x_2 \leq 16$$

$$x_1 + x_2 \geq 3$$

$$x_1 \geq 0, x_2 \geq 0$$

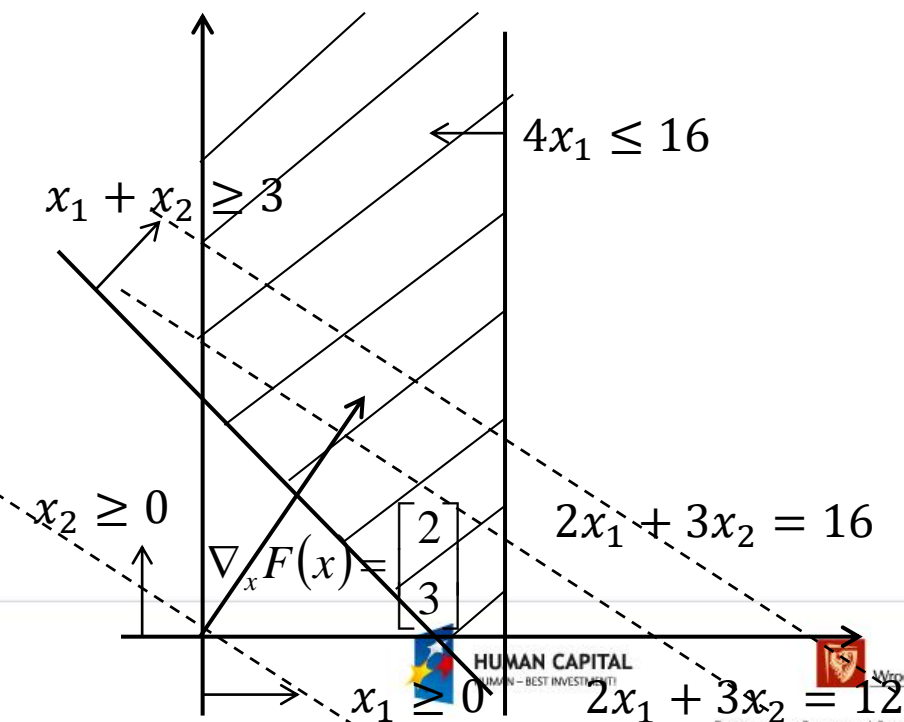

Non constrained solution





General problem formulation

$$x^* \rightarrow F(x^*) = \min_{x \in \mathcal{D}_x} F(x)$$

$$\mathcal{D}_x = \{x \in R^S, \varphi_l(x) = 0, l = 1, 2, \dots, L, \psi_m(x) \leq 0, m = 1, 2, \dots, M\}$$

$$F(x) = c^T x = \sum_{s=1}^S c_s x^{(s)}$$

$$\varphi_l(x) = a_l^T x - b_l = \sum_{s=1}^S a_{ls} x^{(s)} - b_l = 0 \quad l = 1, 2, \dots, L$$

$$\psi_m(x) = a_m^T x - b_m \leq 0 = \sum_{s=1}^S a_{ms} x^{(s)} - b_m \leq 0 \quad m = 1, 2, \dots, M$$

$$x^{(s)} \geq 0 \quad s = 1, 2, \dots, S$$



Geometric view

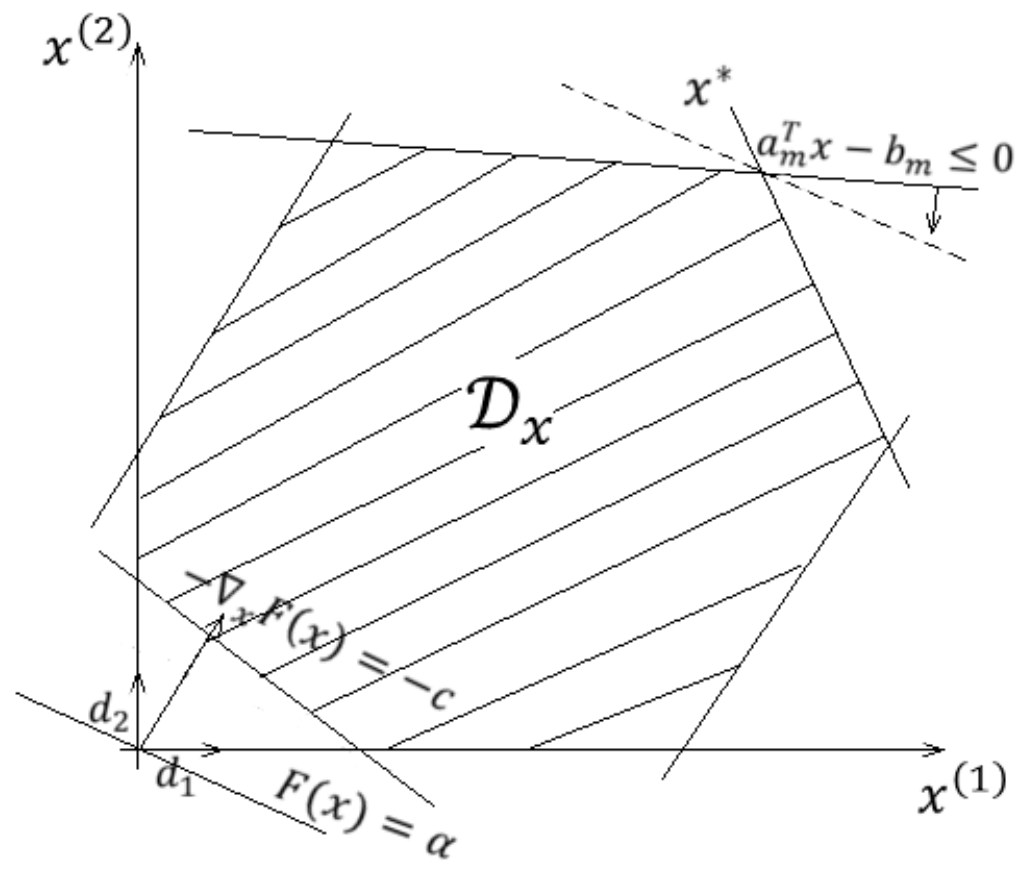

1. Solution is located on a vertex



Geometric view

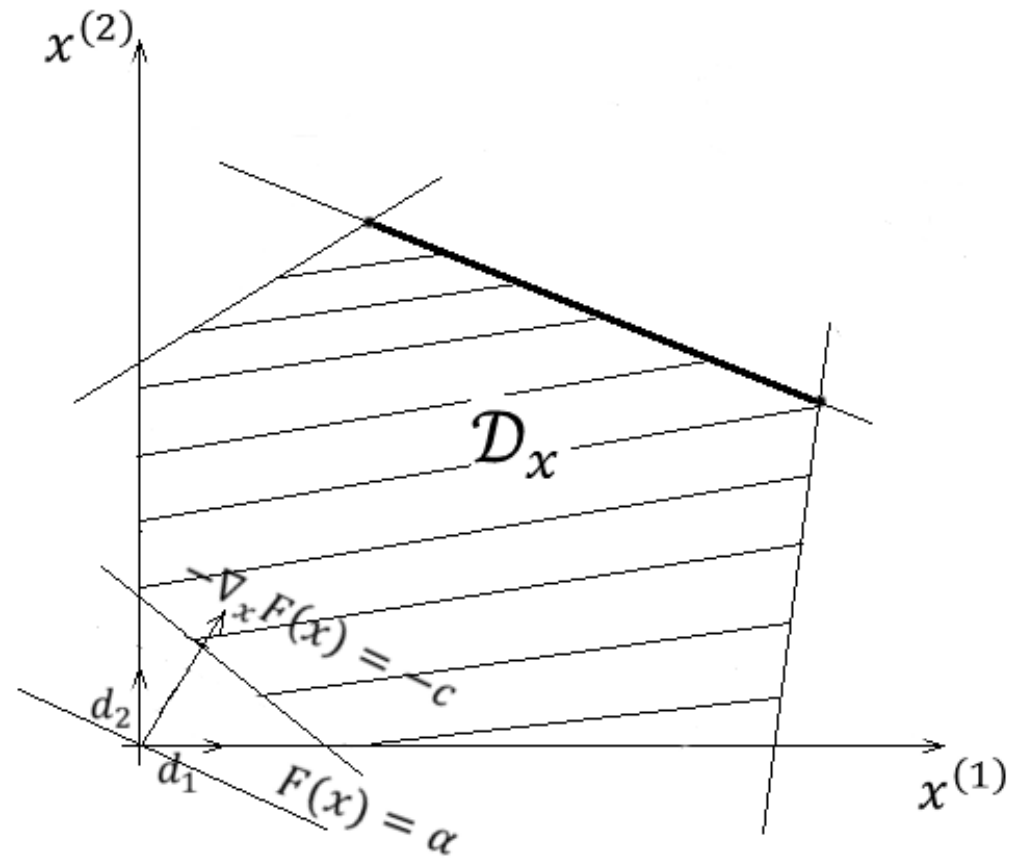

2. Solution is located on an edge



Geometric view

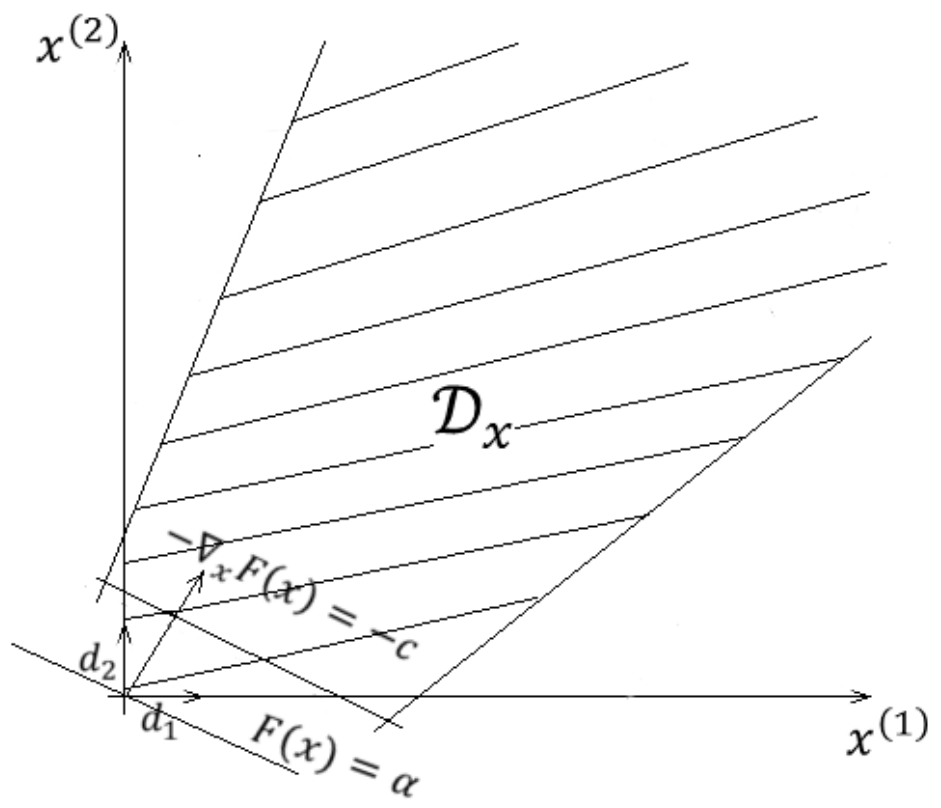

3. Unbounded solution



Example

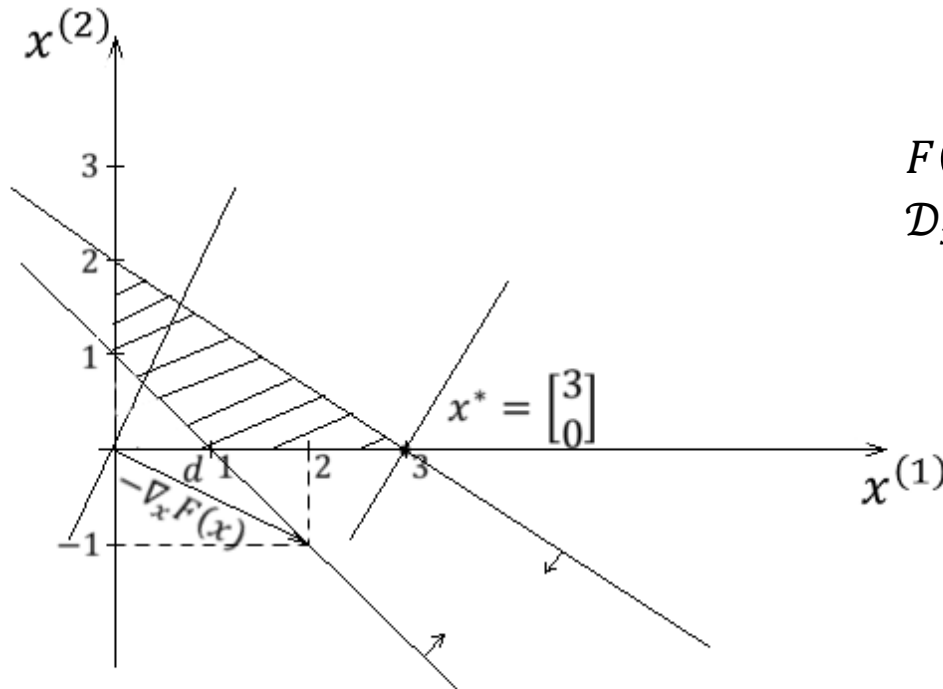

$$F(x) = -2x^{(1)} + x^{(2)}$$

$$\mathcal{D}_x = \{x \in \mathbb{R}^2, -x^{(1)} - x^{(2)} + 1 \leq 0, \\ 2x^{(1)} + 3x^{(2)} - 6 \leq 0, \\ x^{(1)}, x^{(2)} \geq 0\}$$

$$\nabla_x F(x) = \begin{bmatrix} -2 \\ 1 \end{bmatrix} \quad -\nabla_x F(x) = \begin{bmatrix} 2 \\ -1 \end{bmatrix}$$



Standard form

$$F(x) = c^T x$$

$$A: \mathcal{D}_X = \{x \in R^S, Ax - b = 0_L, x \geq 0_S\}$$

or

$$B: \mathcal{D}_x = \{x \in R^S, Ax - b \leq 0_L, x \geq 0_S\}$$

$$c = \begin{bmatrix} c_1 \\ \vdots \\ c_S \end{bmatrix}, \quad b = \begin{bmatrix} b_1 \\ \vdots \\ b_L \end{bmatrix}, \quad x = \begin{bmatrix} x^{(1)} \\ \vdots \\ x^{(S)} \end{bmatrix}, \quad A_{S \times L} = \begin{bmatrix} a_{11} & \cdots & a_{1S} \\ \vdots & \ddots & \vdots \\ a_{L1} & \cdots & a_{LS} \end{bmatrix}$$



$$B \rightarrow A$$

$$1^\circ \quad a_L^T x - b_l \leq 0 \quad \text{we introduce slack variables} \\ x_{S+1} \geq 0$$

$$a_l^T x + x_{S+1} - b_l = 0$$

or

$$\bar{a}_l = \begin{bmatrix} a_{L1} \\ \vdots \\ a_{LS} \\ 1 \end{bmatrix}, \bar{x} = \begin{bmatrix} x^{(1)} \\ \vdots \\ x^{(S)} \\ x^{(S+1)} \end{bmatrix}, \bar{c} = \begin{bmatrix} c_1 \\ \vdots \\ c_S \\ 0 \end{bmatrix}$$

$$F(x) = \bar{c}^T \bar{x}$$

$$\bar{a}_l^T \bar{x} - b_L = 0$$



$A \rightarrow B$

$$2^\circ \quad a_l^T x - b_l = 0 \equiv \begin{cases} a_l^T x - b_l \leq 0 \\ -a_l^T x + b_l \leq 0 \end{cases}$$

3° $x^{(s)}$ – is bounded

$$x^{(s)} = x^{(s)'} - x^{(s)''}$$

$$x^{(s)'} \geq 0, \quad x^{(s)''} \geq 0$$

$$\bar{x} = \begin{bmatrix} x^{(1)} \\ \vdots \\ x^{s-1} \\ x^{(s)'} \\ x^{(s)''} \\ x^{s+1} \\ \vdots \\ x^s \end{bmatrix}, \quad \bar{c} = \begin{bmatrix} c_1 \\ \vdots \\ c_{s-1} \\ c_s \\ -c_s \\ c_{s+1} \\ \vdots \\ c_s \end{bmatrix}, \quad \bar{a}_l = \begin{bmatrix} a_{l1} \\ \vdots \\ a_{ls-1} \\ a_{ls} \\ -a_{ls} \\ a_{ls+1} \\ \vdots \\ a_{ls} \end{bmatrix}$$



$$F(x) = -2x^{(1)} + x^{(2)}$$

$$-x^{(1)} - x^{(2)} + 1 \leq 0 \rightarrow -x^{(1)} - x^{(2)} + x^{(3)} + 1 = 0 \quad x^{(3)} \geq 0$$

$$2x^{(1)} + 3x^{(2)} - 6 \leq 0 \rightarrow 2x^{(1)} + 3x^{(2)} + x^{(4)} - 6 = 0 \quad x^{(4)} \geq 0$$

$$A = \begin{bmatrix} -1 & -1 & 1 & 0 \\ 2 & 3 & 0 & 1 \end{bmatrix}, \quad b = \begin{bmatrix} -1 \\ 6 \end{bmatrix},$$

$$x = \begin{bmatrix} x^{(1)} \\ x^{(2)} \\ x^{(3)} \\ x^{(4)} \end{bmatrix}, \quad c = \begin{bmatrix} -2 \\ 1 \\ 0 \\ 0 \end{bmatrix}$$



$$F(x) = c^T x$$

$$\mathcal{D}_X = \{x \in R^S: Ax - b = 0_L, \quad x \geq 0\}$$

$$L(x, \lambda) = c^T x + \lambda^T (Ax - b) - \mu^T x$$

$$\nabla_x L(x, \lambda) = c + A^T \lambda - \mu = 0_S$$

$$\nabla_\lambda L(x, \lambda) = Ax - b = 0_L \quad !!!$$

$$\mu^T \nabla_\mu L = \mu^T x = 0$$

$$\mu \geq 0_S$$

$$x \geq 0_S$$



Feasible solution $x \in \mathcal{D}_x$

$$Ax = b \quad \text{Rz}(A) = L \quad S \geq L$$

Basic solution

$$x^B = B^{-1}b \quad B - \text{matrix containing } L \text{ kolumn of the matrix } A$$

the total number of basic solutions is at most:

$$\frac{S!}{L!(S-L)!}$$

Basic feasible solution $x^B \geq 0_L$

Not degenerated basic feasible solution $x^B > 0_L$



The simplex method

1. Changing the basis
2. Convergence criteria – the stopping condition
3. Generation of initial feasible solution
4. Dealing with degenerate basic solutions



$$Ax = b \quad x_B = B^{-1}b \text{-- the basic solution}$$

$$x_B = B^{-1}Ax$$

$$Ax - b = 0_L \quad /B^{-1}$$

$$B^{-1}Ax - B^{-1}b = 0_L$$

$$cx = cx - c_B(B^{-1}Ax - B^{-1}b) = (c - c_B B^{-1}A)x - c_B B^{-1}b$$



The simplex method

1. Generation of initial basis
2. Checking $c - c_B B^{-1} A \geq 0_S$. If it holds, then x_B is basic feasible solution $x = [x_B \ 0]$
3. Such a k that $c_k - z_k = \min_{1 \leq s \leq S} (c_s - z_s)$ is introduced to the basis
4. Checking, whether $h_k \leq 0$, if it holds true – solution is unbounded
5. Removing such l from the basis, for which:

$$\frac{h_{l0}}{h_{lk}} = \min_{1 \leq s \leq S} \left\{ \frac{h_{s0}}{h_{sk}}, h_{sk} > 0 \right\}$$

$$6. \quad I_B := I_B \setminus \{l\} \cup \{k\}$$

$$I_B = \{j \in \{1, 2, \dots, S\} \mid x^{(j)} \text{ belongs to the basis} \}$$



			c_1	...	c_k	...	c_s		
Zmienne bazowe	c_B	h_0	h_1	...	h_k	...	h_s	$\frac{h_{s0}}{h_{sk}}$	$h_{sk} \geq 0$
x_{j1}	c_{j1}	h_{10}	h_{11}	...	h_{1k}	...	h_{1s}		
\vdots	\vdots	\vdots	\vdots	\vdots	\vdots	\vdots	\vdots		
x_{jl}	c_{jl}	h_{l0}	h_{l1}	...	h_{lk}	...	h_{ls}		
\vdots	\vdots	\vdots	\vdots	\vdots	\vdots	\vdots	\vdots		
x_{jL}	c_{jL}	h_{L0}	h_{L1}	...	h_{Lk}	...	h_{Ls}		
			$c_1 - z_1$...	$c_k - z_k$...	$c_s - z_s$		

←



$$z_k = \sum_{s \in I_B} c_s h_{sk}$$

$$\begin{aligned} & \uparrow \\ h'_{ls} & := \frac{h_{ls}}{h_{lk}}; & h'_{is} & = h_{is} - \frac{h_{ik} h_{ls}}{h_{lk}} \\ s & = 1, 2, \dots, S & i & = 0, 1, \dots, S \\ & & s & \in I_B \setminus \{l\} \end{aligned}$$



Example

$$F(x) = -2x^{(1)} - 3x^{(2)} + 0x^{(3)} + 0x^{(4)} + 0x^{(5)}$$

$$2x^{(1)} + 2x^{(2)} - 14 \leq 0 \rightarrow 2x^{(1)} + 2x^{(2)} + x^{(3)} = 14$$

$$x^{(1)} + 2x^{(2)} - 8 \leq 0 \quad x^{(1)} + 2x^{(2)} + x^{(4)} = 8$$

$$4x^{(1)} - 16 \leq 0 \quad 4x^{(1)} + x^{(5)} = 16$$

$$F(x) = [-2 \quad -3 \quad 0 \quad 0 \quad 0] \begin{bmatrix} x^{(1)} \\ x^{(2)} \\ x^{(3)} \\ x^{(4)} \\ x^{(5)} \end{bmatrix} \quad \begin{bmatrix} 2 & 2 & 1 & 0 & 0 \\ 1 & 2 & 0 & 1 & 0 \\ 4 & 0 & 0 & 0 & 1 \end{bmatrix} \begin{bmatrix} x^{(1)} \\ x^{(2)} \\ x^{(3)} \\ x^{(4)} \\ x^{(5)} \end{bmatrix} = \begin{bmatrix} 14 \\ 8 \\ 16 \end{bmatrix}$$



			-2	-3	0	0	0		
Zmienne bazowe	c_B	h_0	h_1	h_2	h_3	h_4	h_5		
x_3	0	14	2	2	1	0	0	$\frac{14}{2}$	
x_4	0	8	1	2	0	1	0	$\frac{8}{2}$	→
x_5	0	16	4	0	0	0	1	-	
		0	-2	-3	0	0	0		



$$I_B = \{3, 4, 5\}$$



			-2	-3	0	0	0	
Zmienne bazowe	c_B	h_0	h_1	h_2	h_3	h_4	h_5	
x_3	0	6	1	0	1	-1	0	$\frac{6}{1}$
x_2	-3	4	$\frac{1}{2}$	1	0	$\frac{1}{2}$	0	$\frac{4}{\frac{1}{2}}$
x_5	0	16	4	0	0	0	1	$\frac{16}{4}$
			$-\frac{1}{2}$	0	0	$\frac{3}{2}$	0	

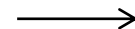



		x_B	-2	-3	0	0	0	
Zmienne bazowe	c_B	h_0	h_1	h_2	h_3	h_4	h_5	
x_3	0	2	0	0	1	-1	$-\frac{1}{4}$	
x_2	-3	2	0	1	0	$\frac{1}{2}$	$-\frac{1}{8}$	
x_1	-2	4	1	0	0	0	$\frac{1}{4}$	
			0	0	0	$\frac{3}{2}$	$\frac{1}{8}$	

≥ 0

The final solution [4 2 2 0 0]



Finding initial feasible basic solution (additional task)

$$Ax = b$$

$$x \geq 0_S$$

Artificial variables:

$$Ax + Ix_a = b \quad x \geq 0, x_a \geq 0$$

Additional task

$$\min_{x_a} 1^T x_a$$



The two phase simplex method

$$F(x) = c^T x + M1^T x_a$$

Constraints

$$Ax + IX_a = b, x \geq 0, x_A \geq 0$$